



## Drum Crusher

*Reduce Disposal Costs*

- **60,000 lbs. compaction force** reduces drums to 4" pancakes
- **Rugged**, fully enclosed compaction chamber
- **Automatic** push button controls
- **Safety interlock** prevents operation when door is open
- **Second compaction head** quickly converts drum crusher to in-drum compaction
- **Location plate** keeps drums centered in chamber
- **Forklift pockets** allow for easy removal of heavy compacted drums
- **Large feed area** accepts even 5-gallon pails for in-drum compacting
- **Options** include xp motor,

# ner/In-Drum Compactor

Costs

reduces drums

reaction chamber

is

ation if door

quickly converts  
factor



- **Options** include xp motor, drip pan, remote operator station and platen spike

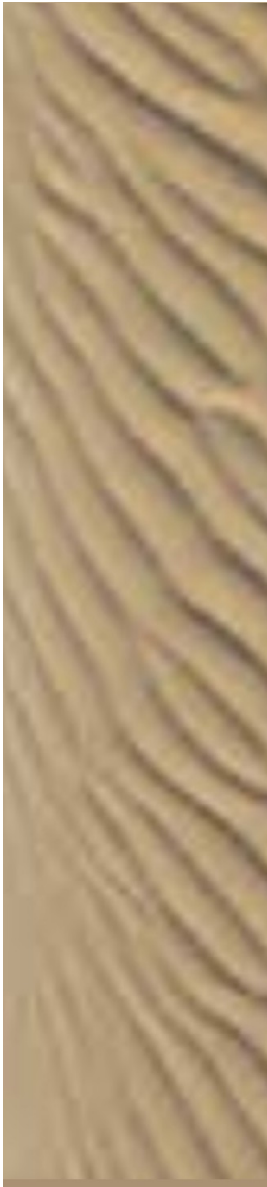

**Totally  
Drum C  
Class 1  
Areas**

---

**BENKO**

---

5350 Evergreen Pkwy, Sheffield Villa  
[www.benkoproducts.co](http://www.benkoproducts.co)



EIGHT DRUMS CRUSH TO A HEIGHT OF 4" EACH TO  
OCCUPY THE SPACE OF ONE DRUM

**ully Explosion Proof  
m Crusher For Use In  
ss 1, Div 1 Hazardous  
as**

---

**RODUCTS INC.**

---

Village, Ohio 44054 (440)934-2180 Fax(440)934-4052  
s.com E-mail: info@benkoproducts.com

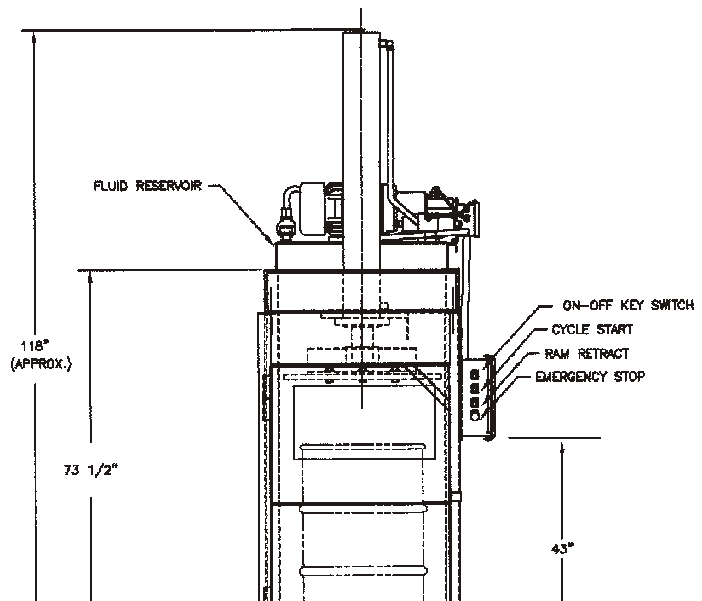
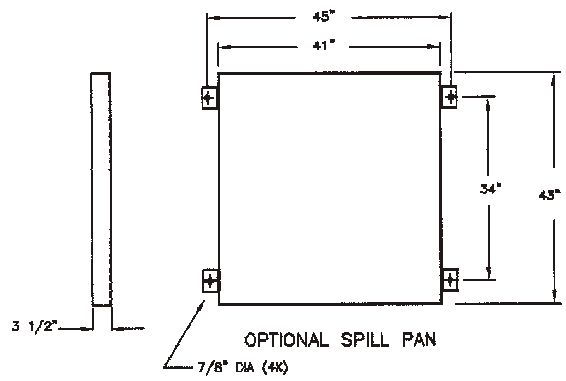

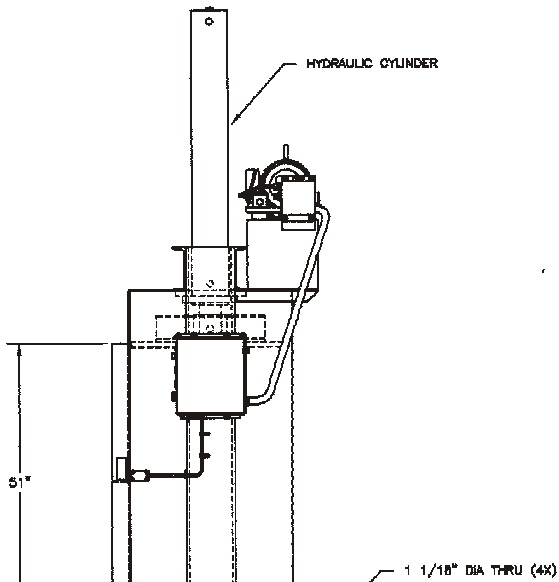
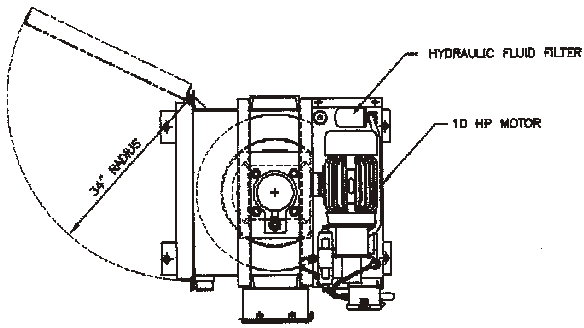

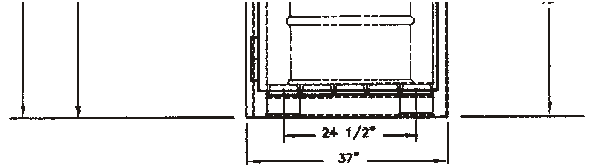

## **SPECIFICATIONS**

OVERALL HEIGHT	117 1/2"
OVERALL WIDTH	43"
OVERALL DEPTH	38"
CRUSHING/PACKING CHAMBER HEIGHT	48"
CYLINDER	6" bore x 45" stroke x
MOTOR	10 h.p. 3/60/208-240-4
COMPACTING FORCE	60,759 lbs.
SYSTEM PRESSURE	2,150 psi
SHIPPING WEIGHT	2,500 lbs.

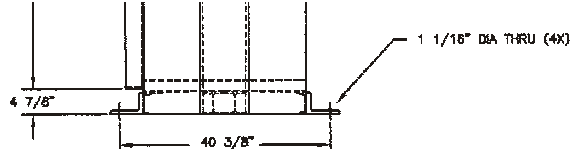

## OPTIONS

- Explosion Proof Motors and Single Phase Motors
- Remote Operator Station
- Drip Pan
- Platen Spike

e x 4" rod

10-480

This document was created with Win2PDF available at <http://www.win2pdf.com>.  
The unregistered version of Win2PDF is for evaluation or non-commercial use only.  
This page will not be added after purchasing Win2PDF.